

GÜVENÇ[®]
5
KALIP SANAYİ

2019 Product Catalogue Kitchen
Ürün Kataloğu Mutfak

STARTS
WITH
PRODUCT
QUALITY
MOLD
ÜRÜNÜN
KALİTESİ
KALIP İLE
BAŞLAR

+10
TONS
Of
Mold
PRODUCTION
CAPACITY+

10TON
KALIP
ÜRETİM
KAPASİTESİ

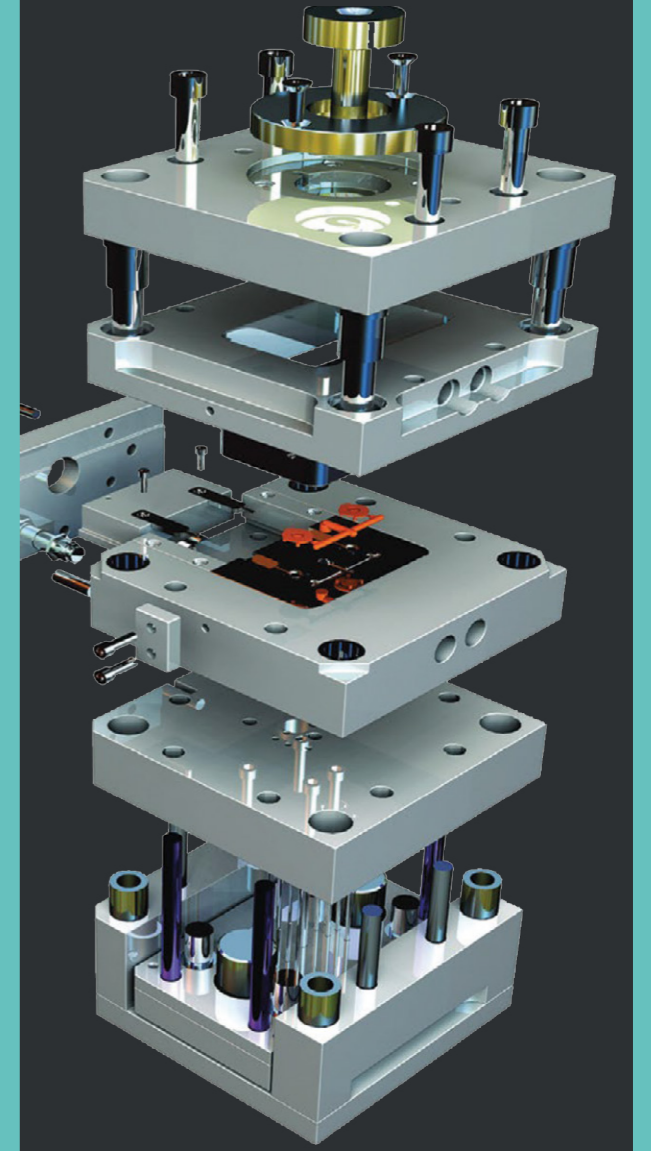

Firmamız ürettiği kalıplarda müşterilerine 1.000.000 baskı sayısına ya da 1 yıla kadar garanti seçeneklerini sunuyor.

Our company provides guaranty options to its customers regarding the molds that it manufactures for 1 years of period or 1.000.000 cycle.

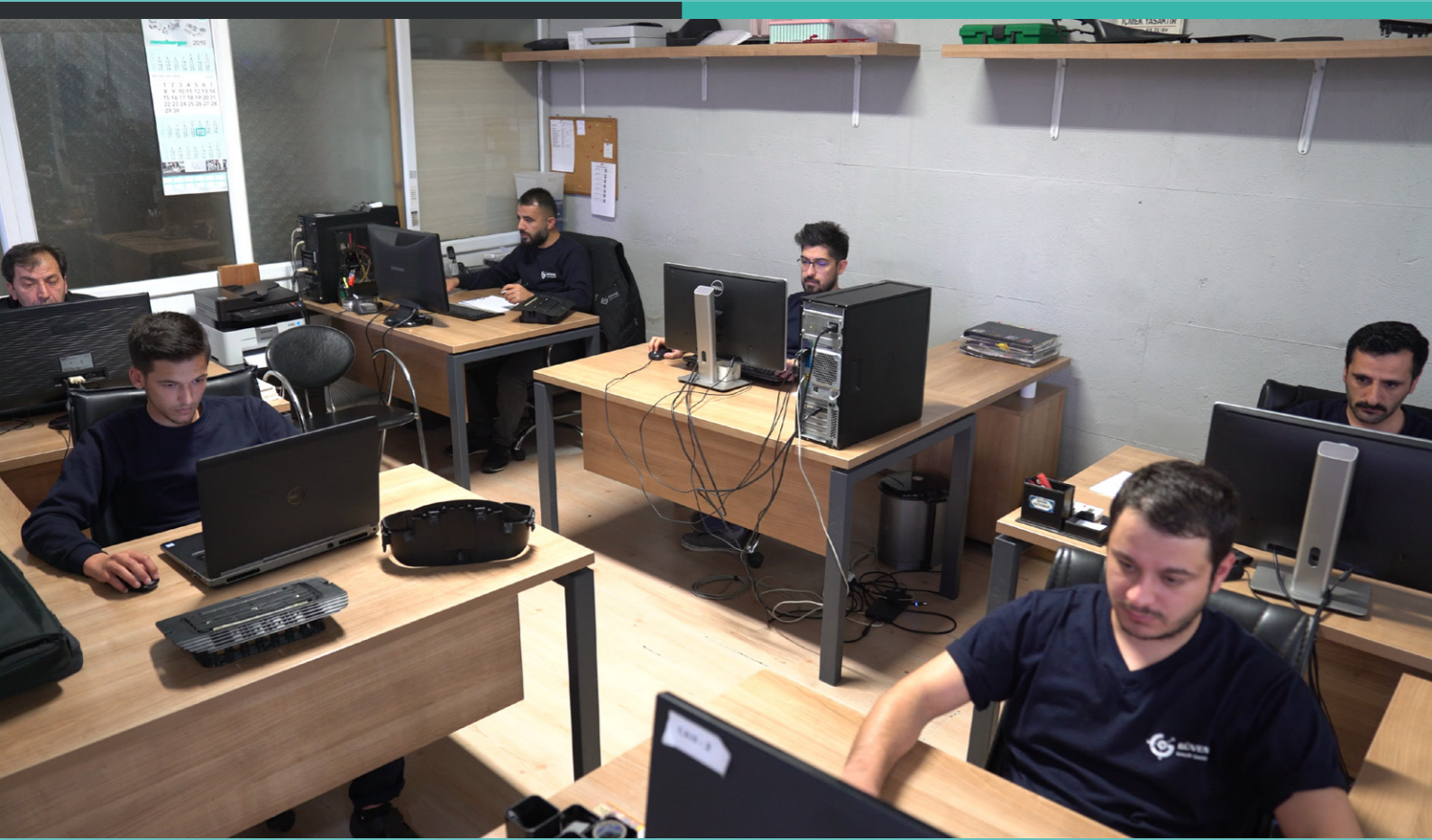

Plastic Injection Mold Design Plastic mold design department importance in the production stage. Our company is aware, Using professional programs such as Solidworks, mold design're doing.

Tasarım departmanının plastik kalıp üretimi aşamalarındaki önemini farkında olan firmamız, Solidworks, gibi alanında profesyonel programlara yaptığı yatırımlar ile müşterisinin her aşamada ihtiyaçlarına karşılık verebilmektedir.

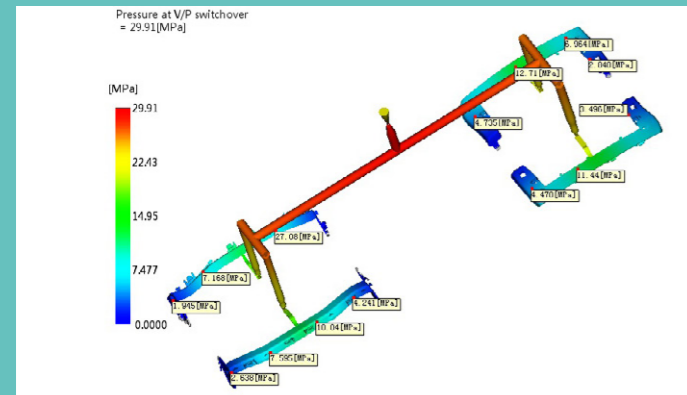

Güvenç Kalıp Sanayi

2003 yılında kurulmuş olup, plastik kalıp sektöründe faaliyetini sürdürmektedir.

Şirketimiz müşterilerimizin ihtiyaçlarına cevap verebilmek için en son teknoloji makine parkuru ile hizmet vermektedir.

Ana sanayi firmaları ile müşterek çalışarak rekabetçi, hızlı ve termin sürelerine bağlı olarak kalıp üretimi yaparak, sektör içerisinde kendine sağlam güvenilir bir yer edinmiştir.

Firmamız gücünü, uzun yıllara dayanan deneyim ve tecrübesinden almaktadır ve gelecekteki yatırımlarını bu doğrultuda revize etmektedir.

Otomotiv Sanayi, Mutfak Gereçleri Sanayi, Gıda ve Ambalaj Sanayi 'ne hizmet veren firmamız bu sanayiler için kalıp tasarımı ve plastik enjeksiyon kalıp üretim mühendisliği konusunda bilgi ve birikimi ile yer almaktadır.

AR-GE Yatırımlı Kalıp imalatlarımız müşterilerimizin global piyasada rekabet etmesine yardımcı olmaktadır.

Güvenç Mold Industry

Established in 2003, our company is engaged in manufacturing plastic molding industry.

Our company is able to respond to the needs of our customers the latest technology to serve with machinery.

Working jointly with industrial firms competitive, fast and adhere to deadlines by manufacturing within the industry itself has been a reliable company.

Our company strength, based on many years of experience and are revised and future investments in this direction has been.

Automotive Industry, Kitchen Industry Food and Packaging Industry for serving our company in this industry mold design and manufacturing plastic injection mold With knowledge and experience in the engineering is located.

Our investment in technology, mold manufacturing customers we are helping to compete in the global market.



PATTERNED
BASKET
MOLD
DESENLI
SEPET
KALIBI

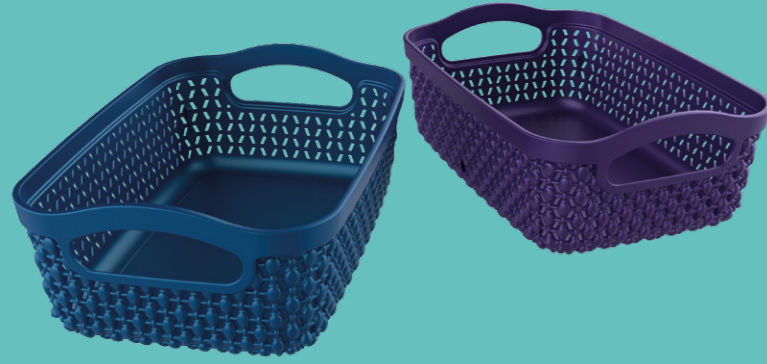

Code: GK 0001

MULTI
STORAGE
BOWL
MOLD
MULTİ
SAKLAMA
KABI
KALIBI

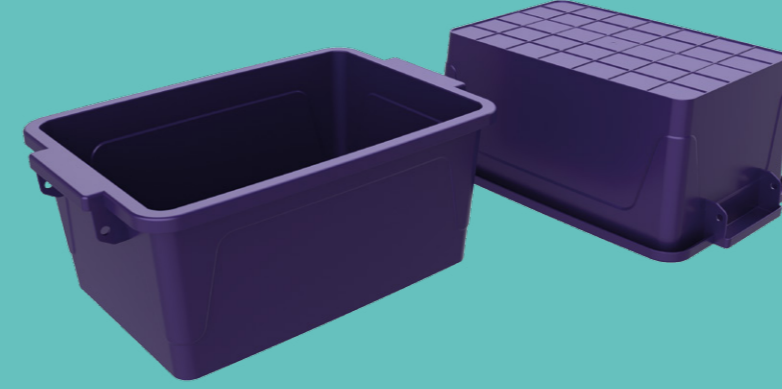

Code: GK 0002

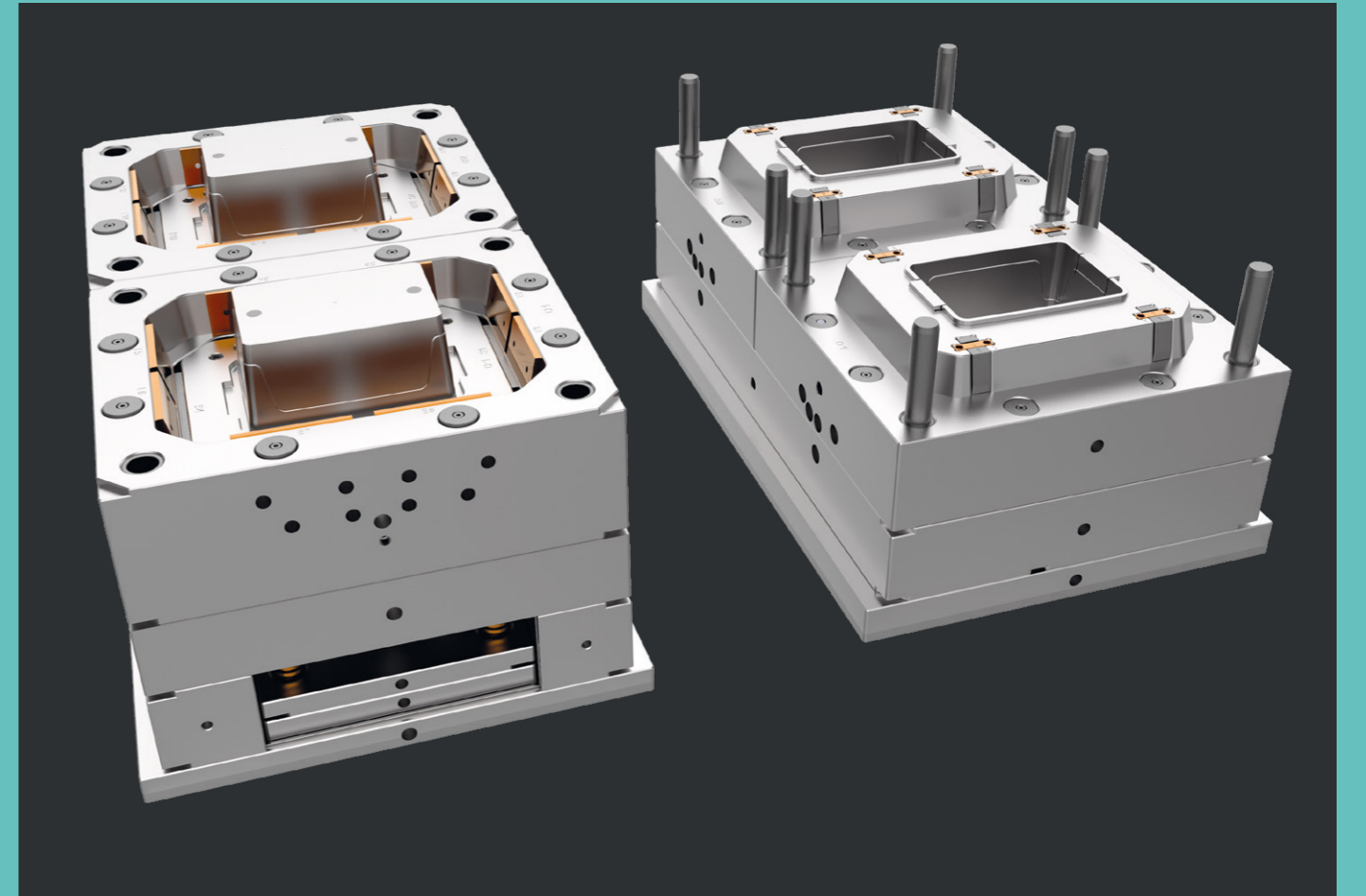
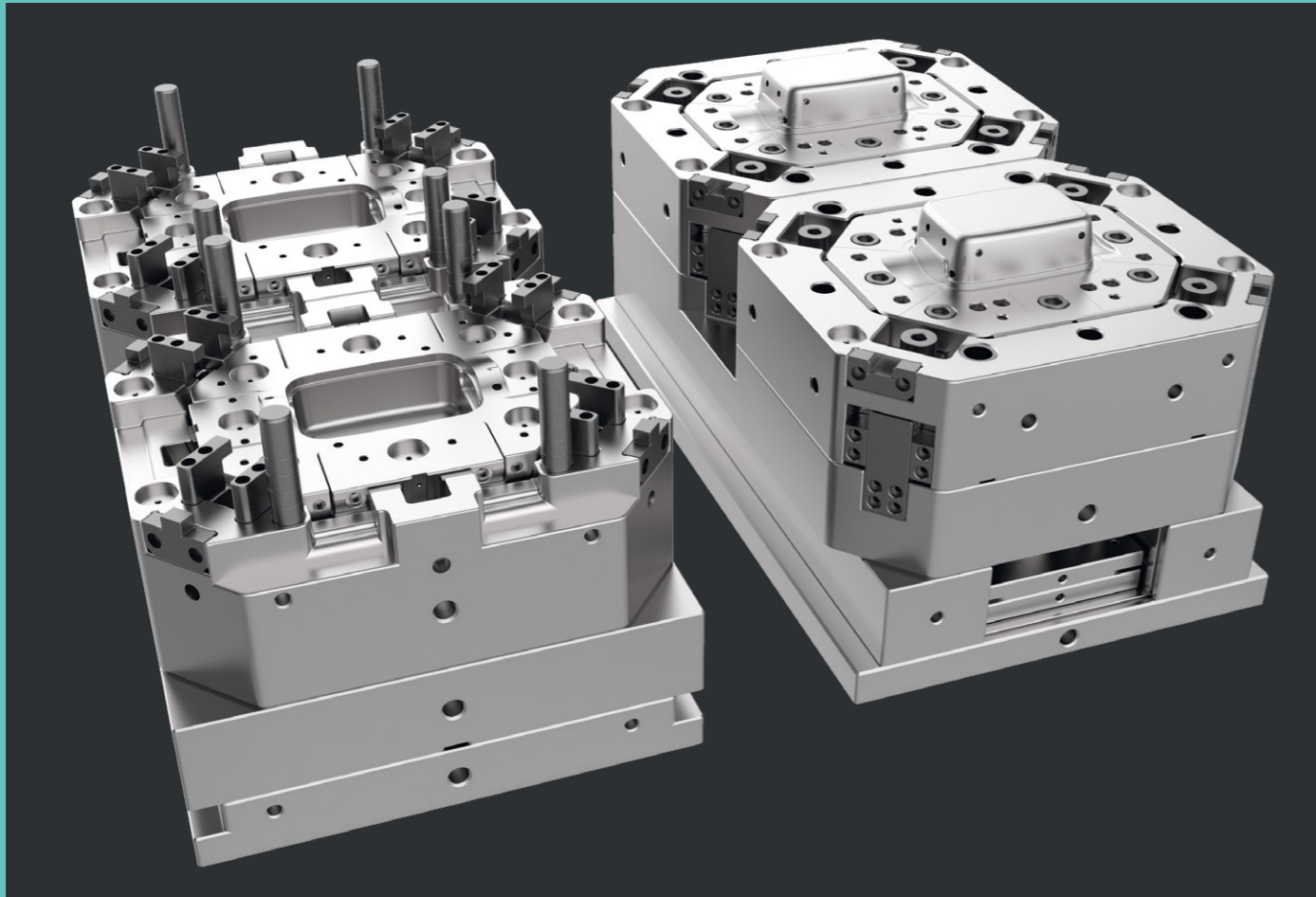

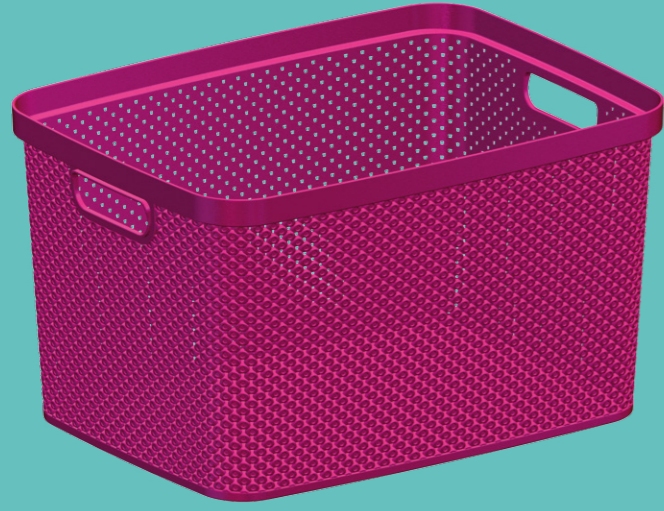

PATTERNED
BASKET
MOLD
DESENLİ
SEPET
KALIBI

Code: GK 0003



3 COMPARTMENT
CUTLERY TRAY
MOLD
3 BÖLMELİ
KAŞIKLIK
KALIBI

Code: GK 0004

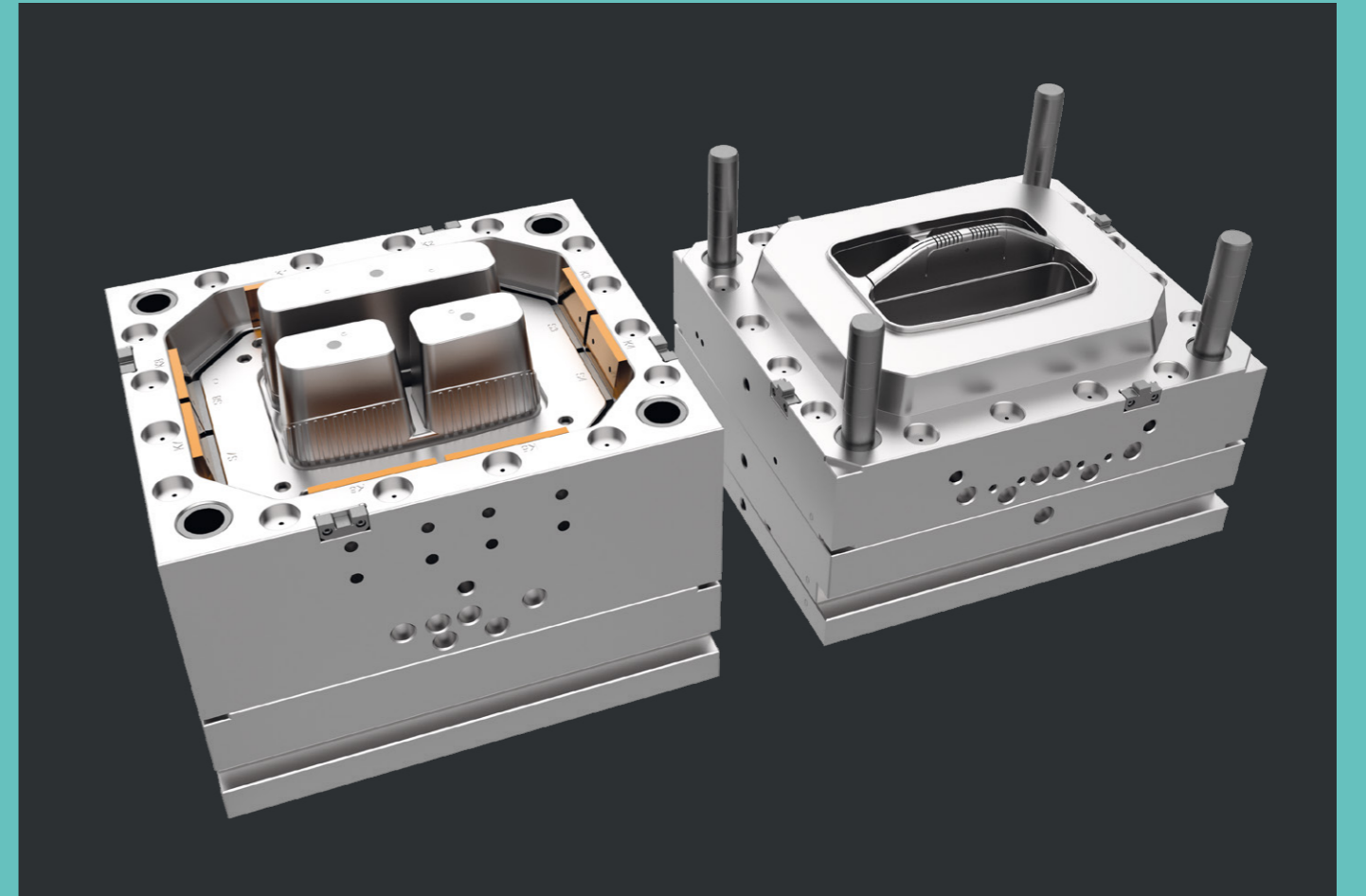
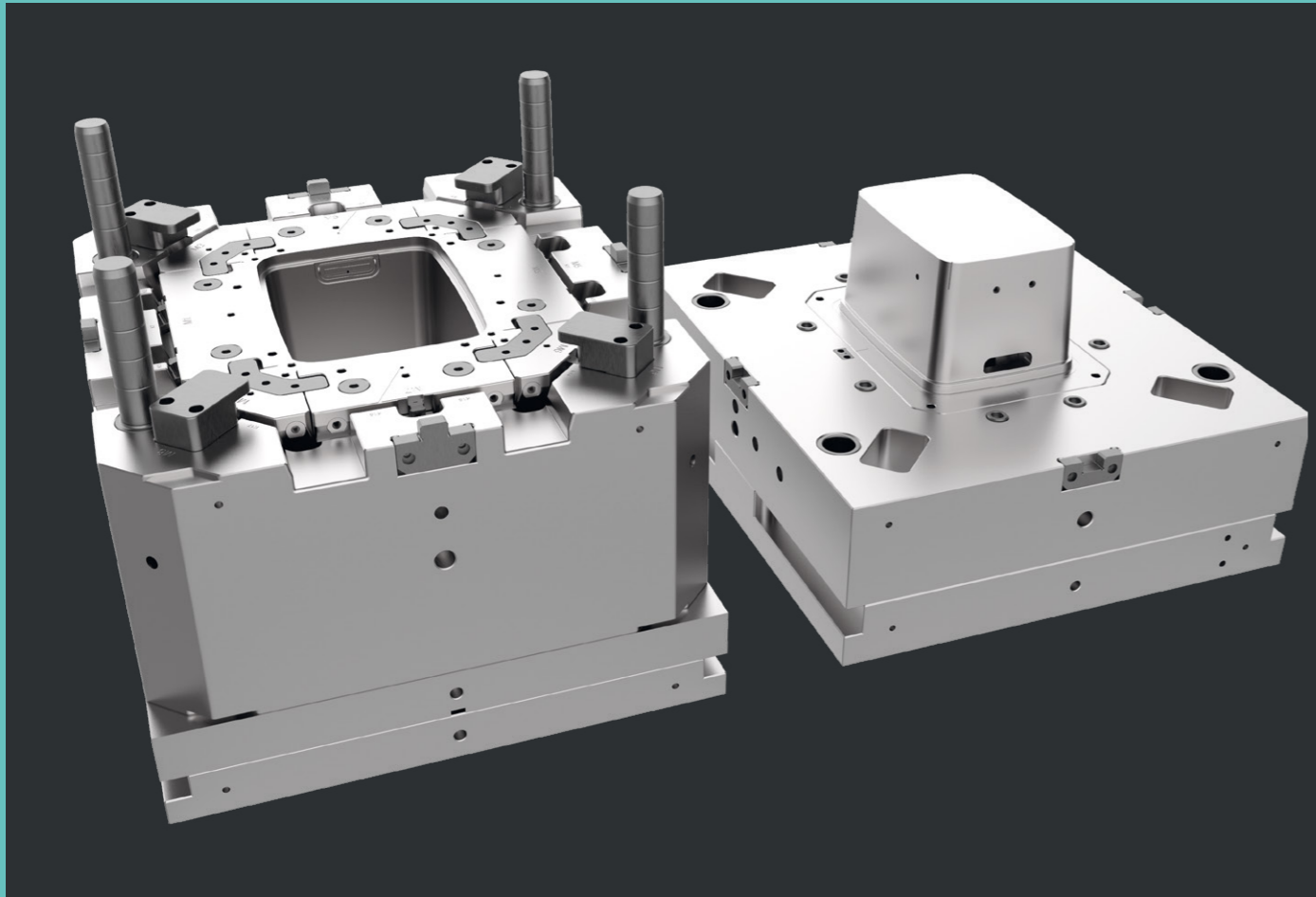



STORAGE
BOWL
MOLD
SAKLAMA
KABI
KALIBI

Code: GK 0005



CUP
MOLD
SAPLI
BARDAK
KALIBI

Code: GK 0006

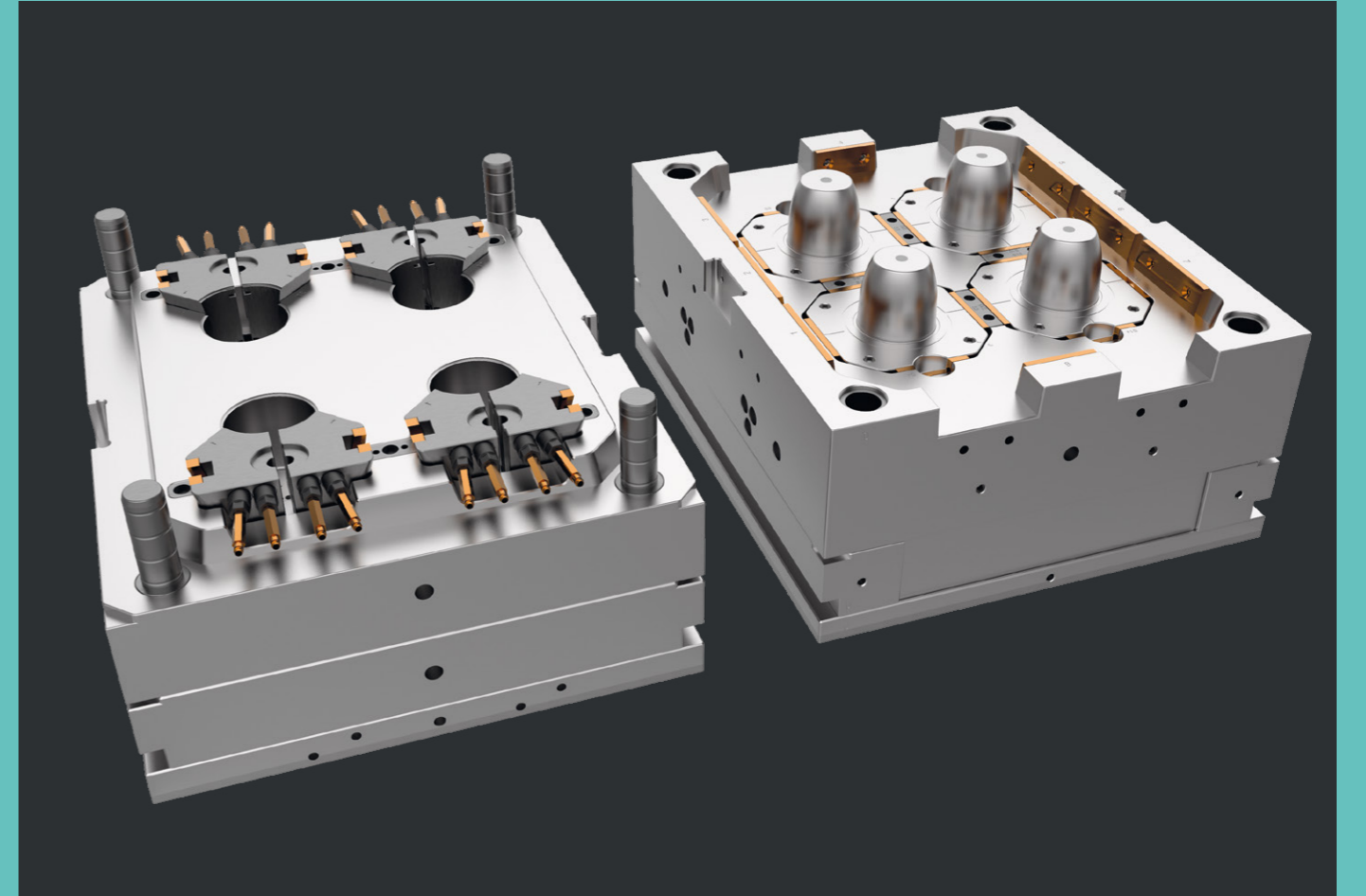
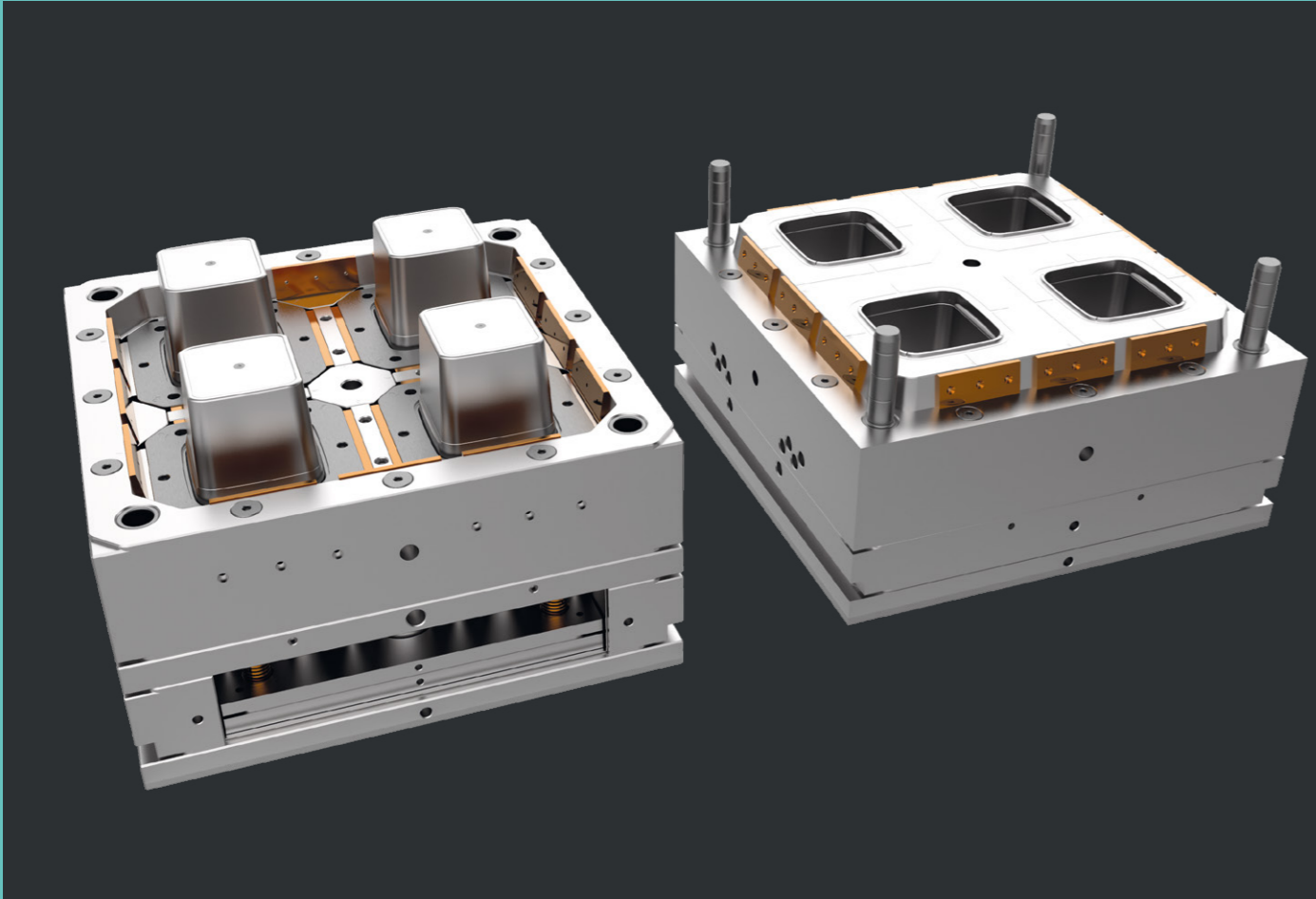



PATTERNED
BASKET
MOLD
DESENLI
SEPET
KALIBI

Code: GK 0007

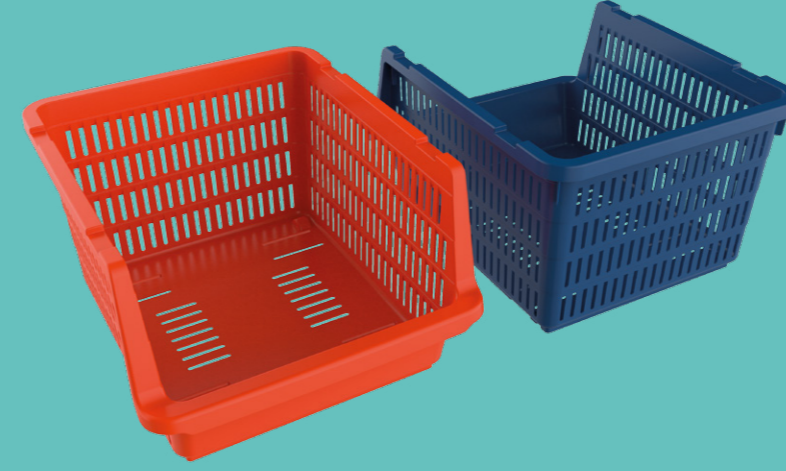

MULTIPURPORSE
ORGANIZER
MOLD
ÇOK AMAÇLI
ORGANİZER
KALIBI

Code: GK 0008

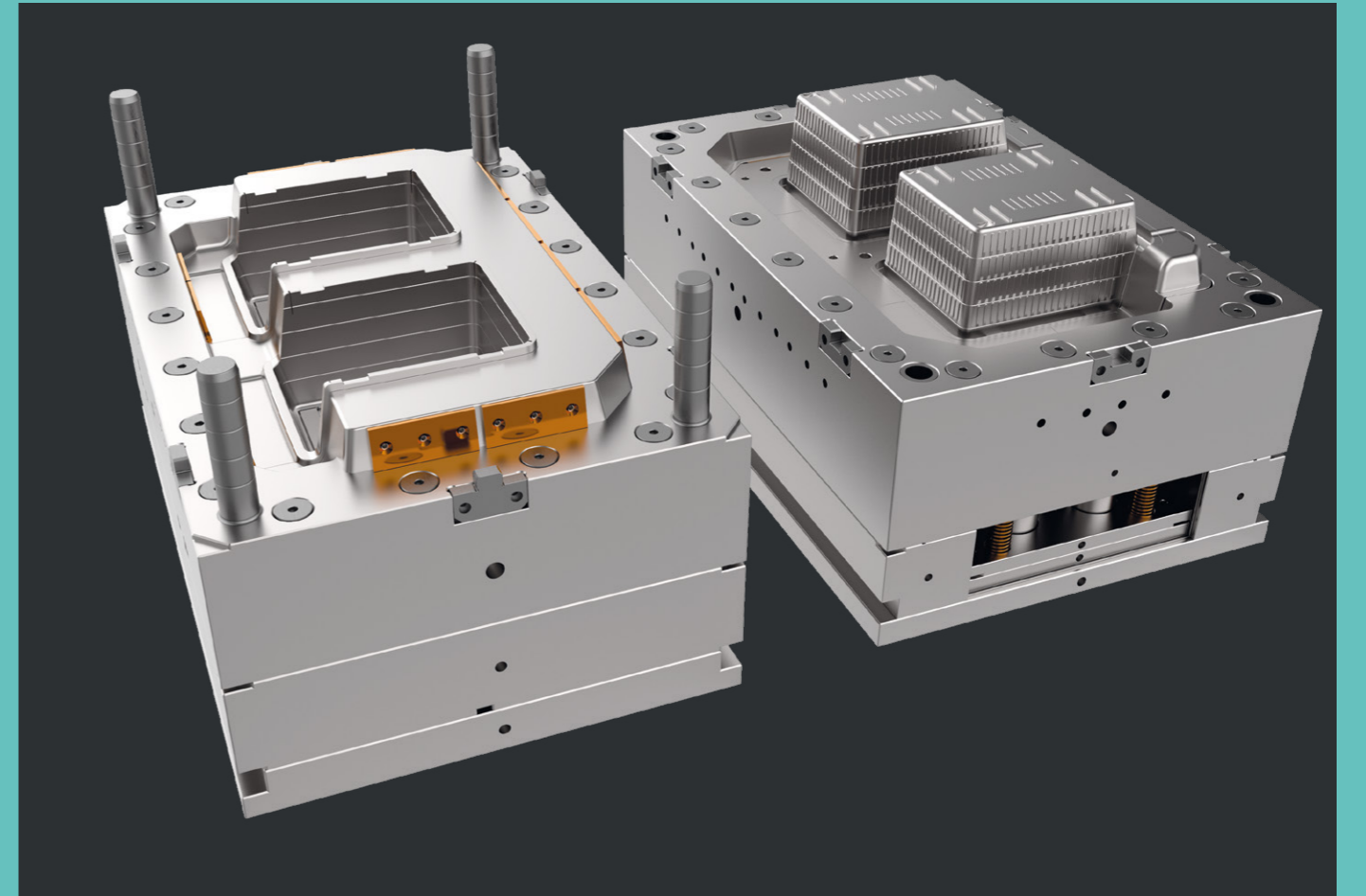
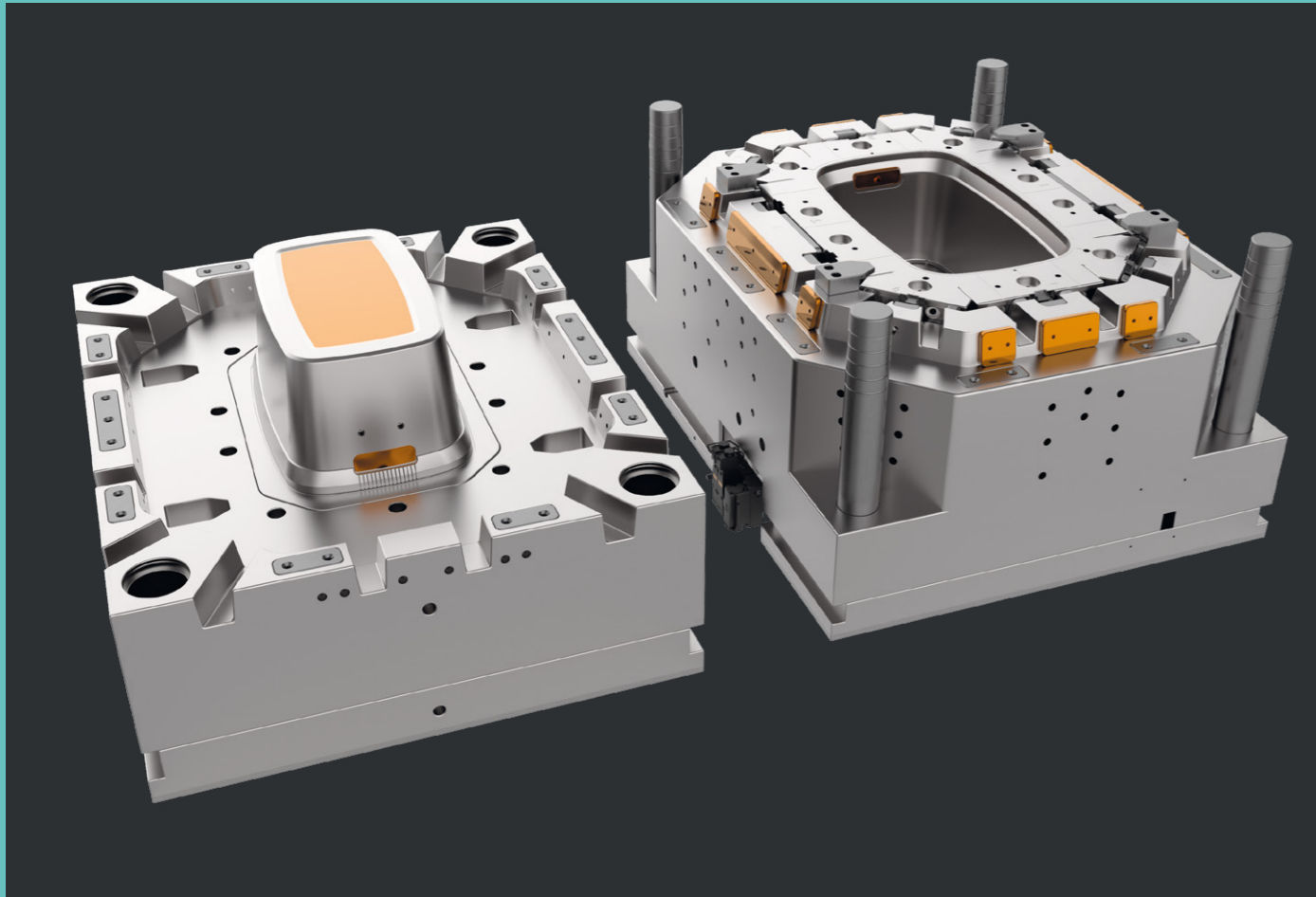

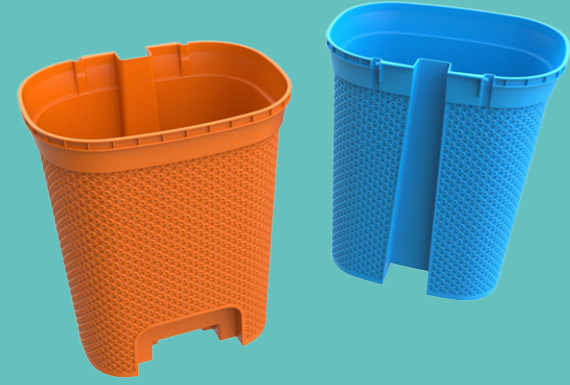

PATTERNED
WASTE BIN-1
MOLD
DESENLİ
ÇÖP KOVASI-1
KALIBI

Code: GK 0009

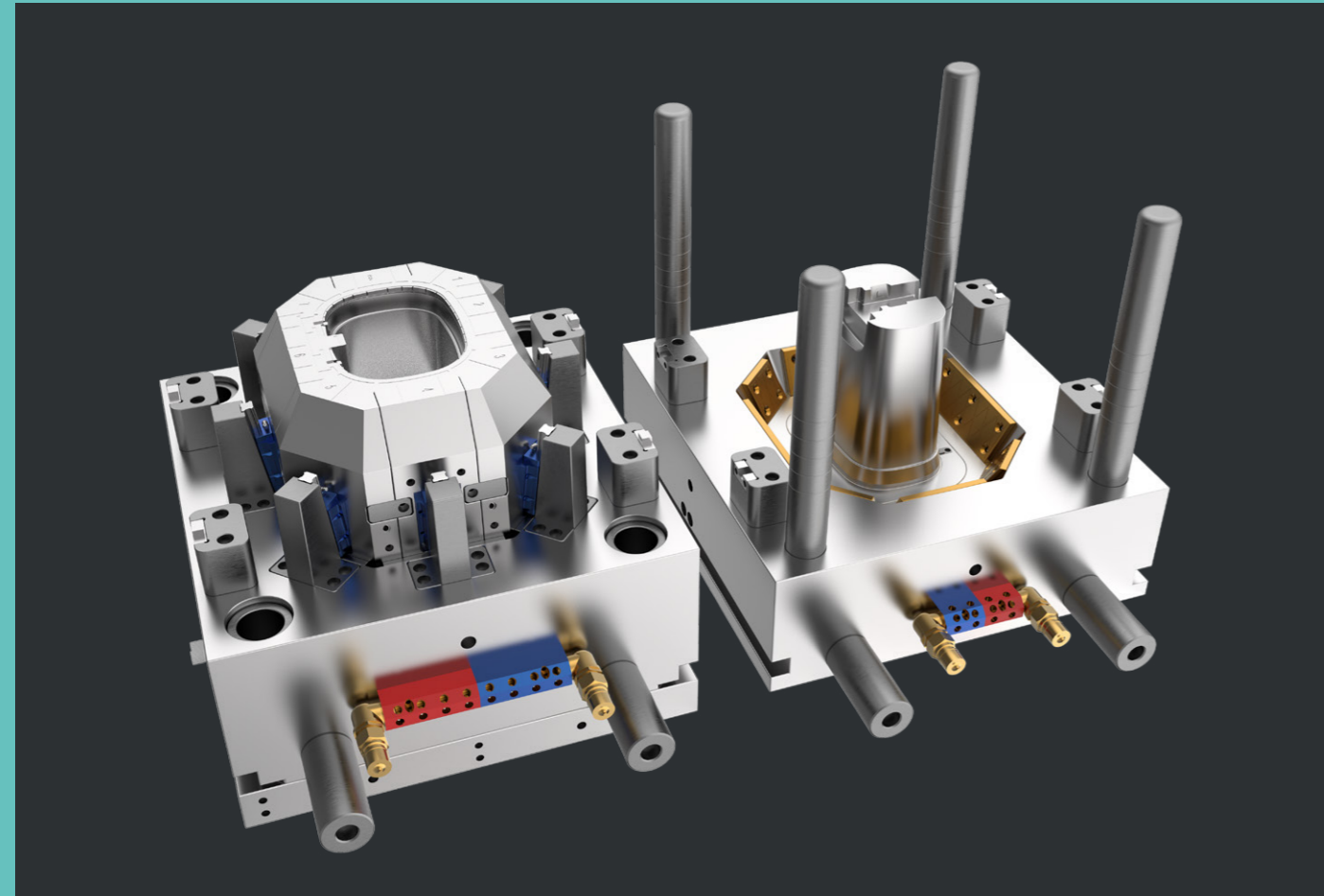

PATTERNED
FILES OF
BASKET
MOLD
DESENLİ
DOSYALIK
KALIBI

Code: GK 0010

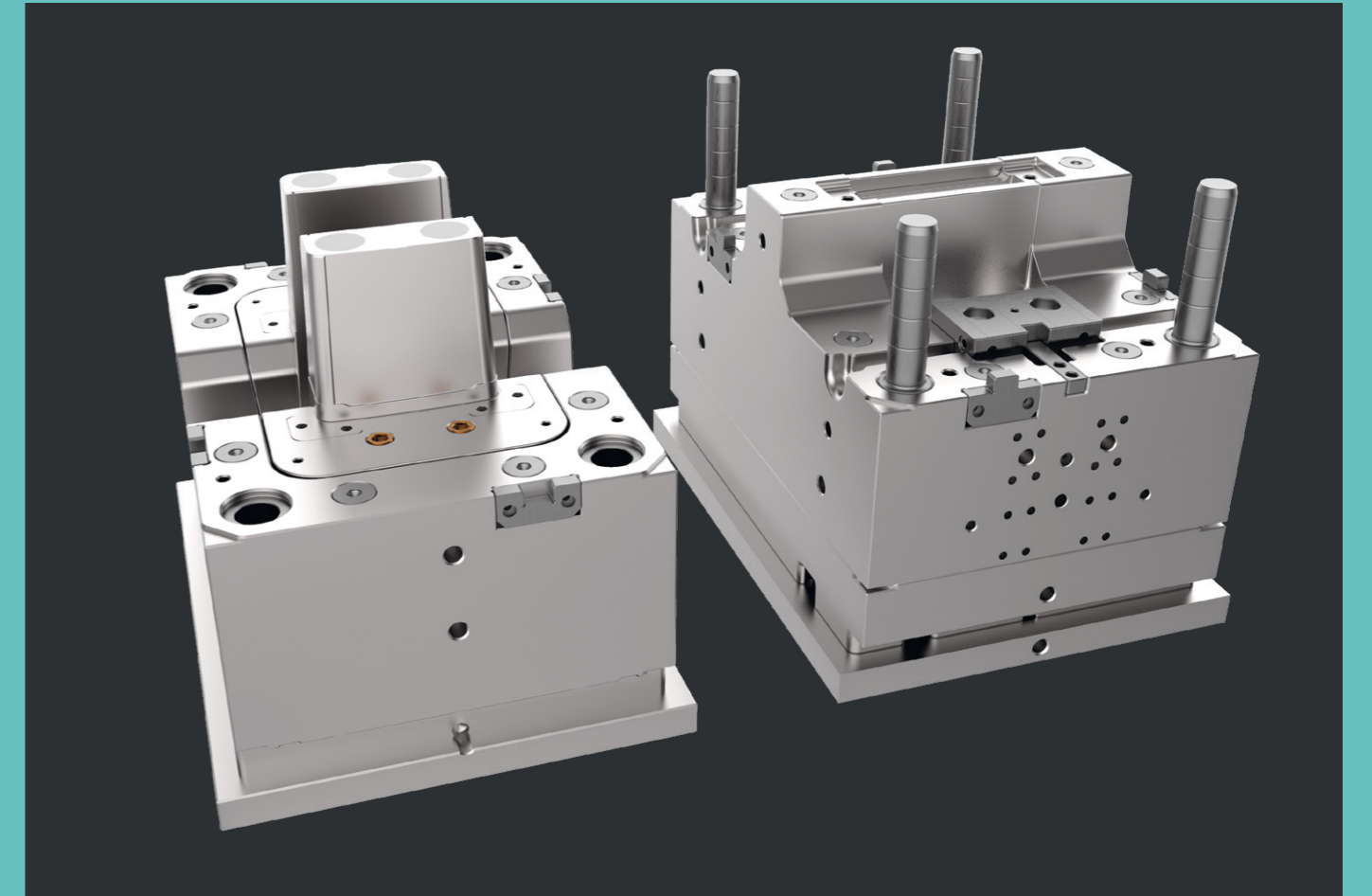

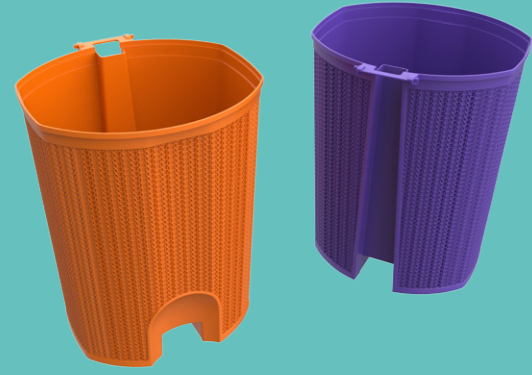

PATTERNED
WASTE BIN-2
MOLD
DESENLİ
ÇÖP KOVASI-2
KALIBI

Code: GK 0011

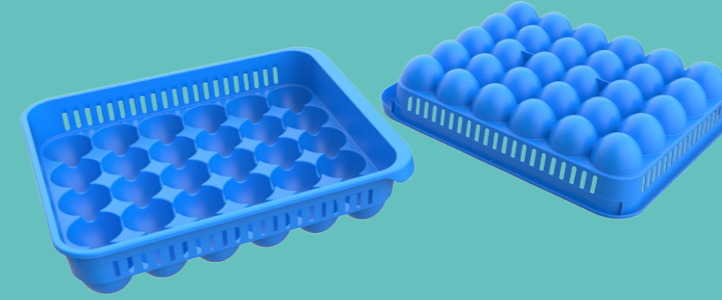
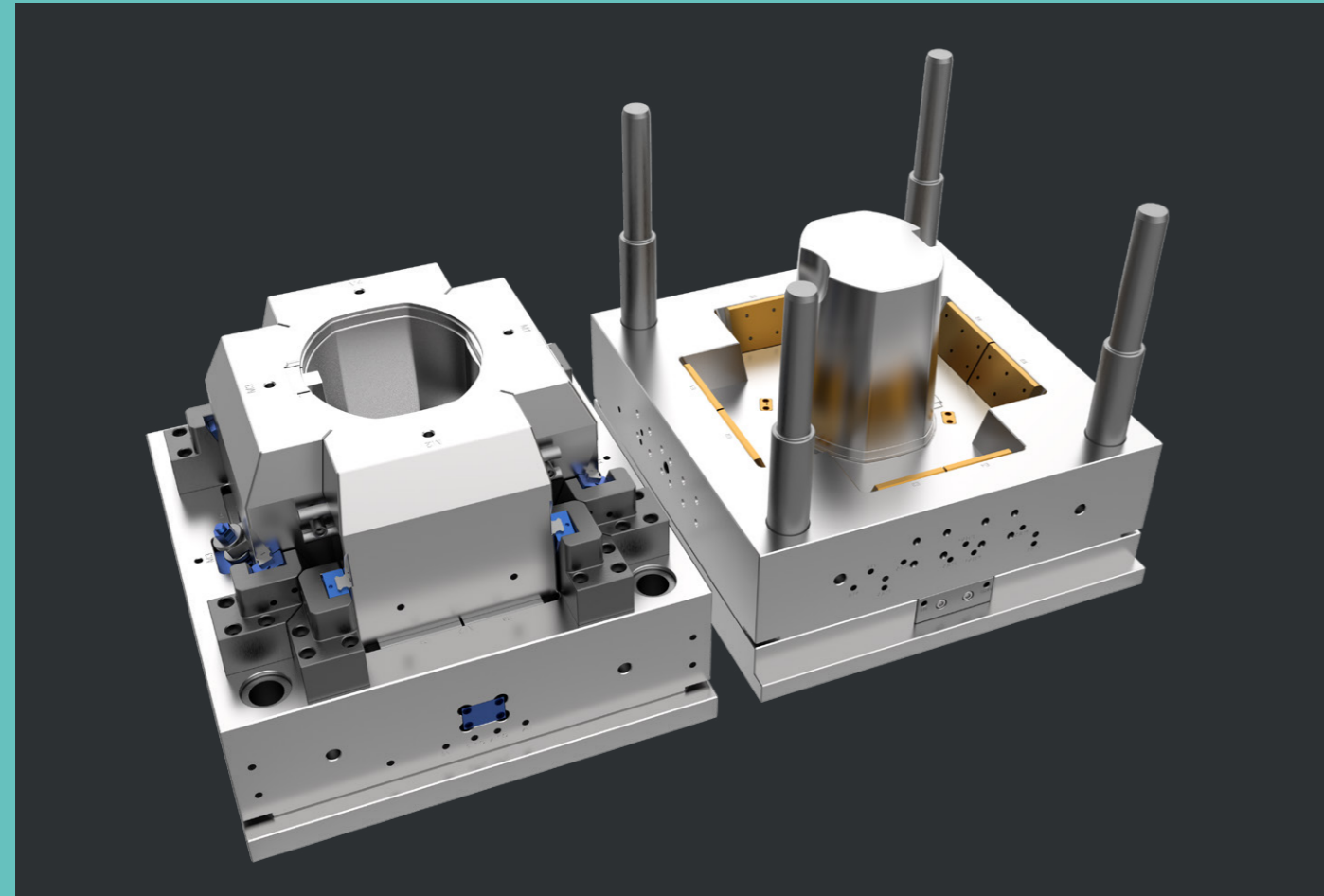

EGG
MOLD

YUMURTALIK
KALIBI

Code: GK 0012

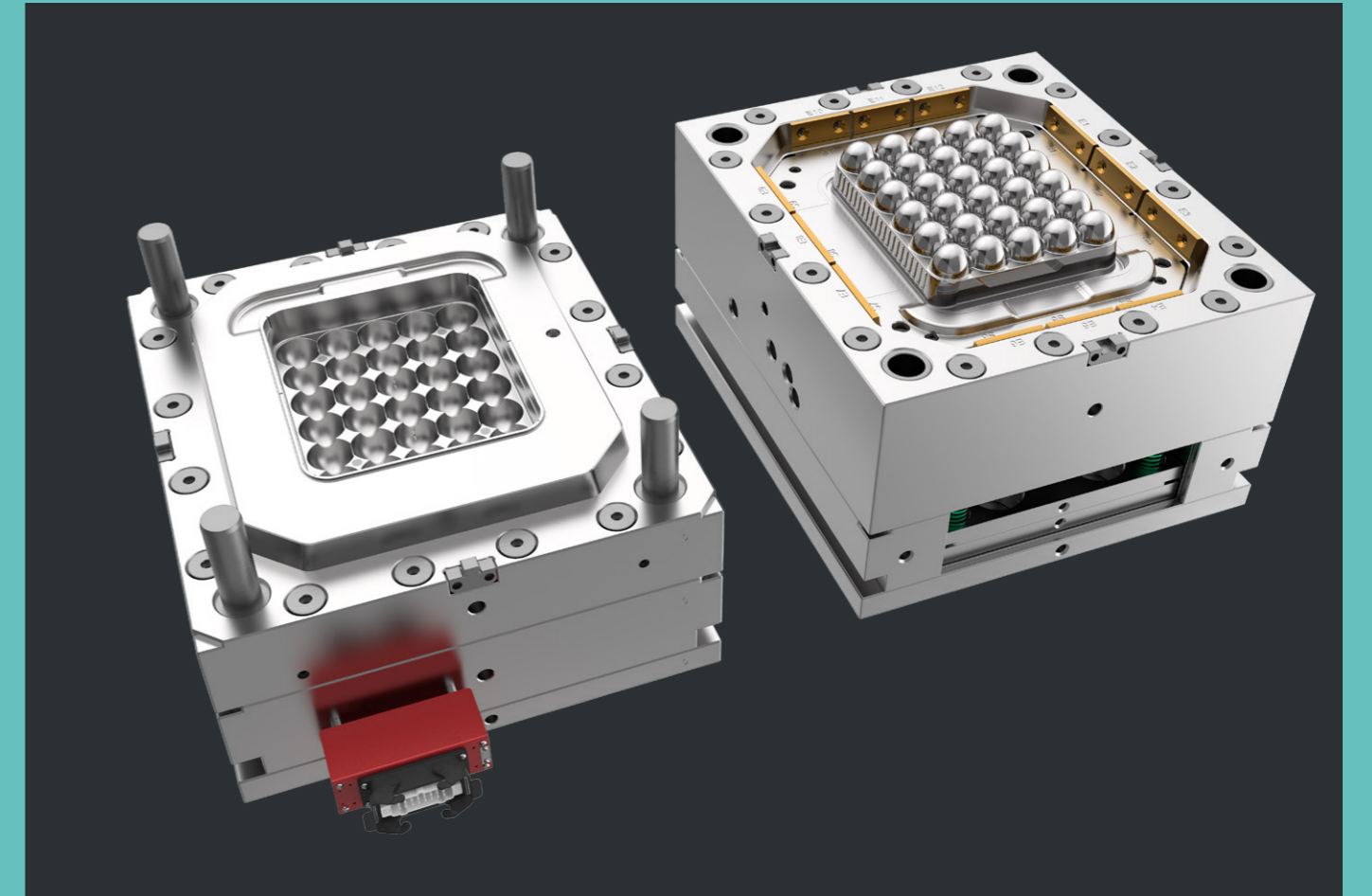

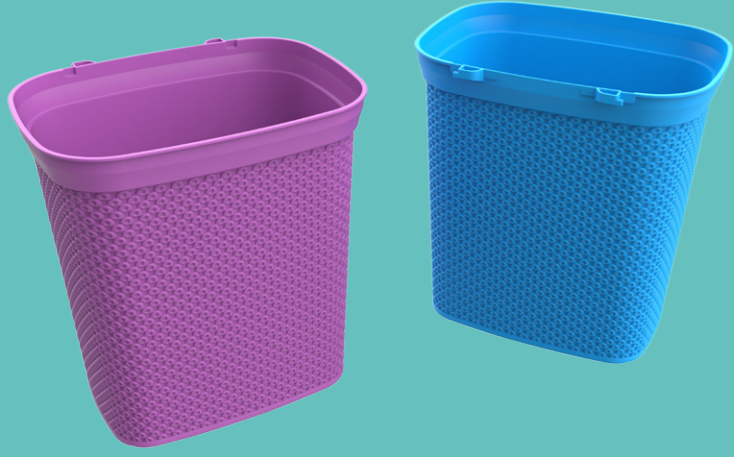

PATTERNED
DETERGENT
MOLD
DESENLI
DETERJANLIK
KALIBI

Code: GK 0013

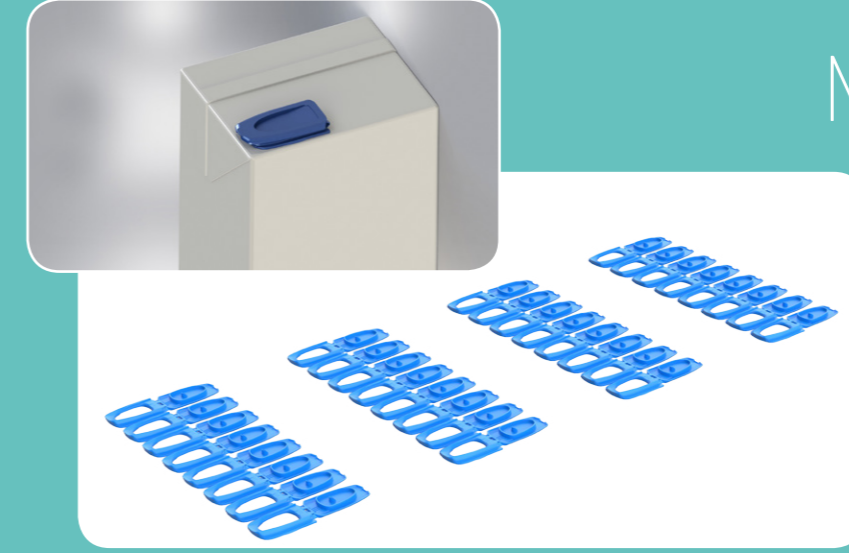
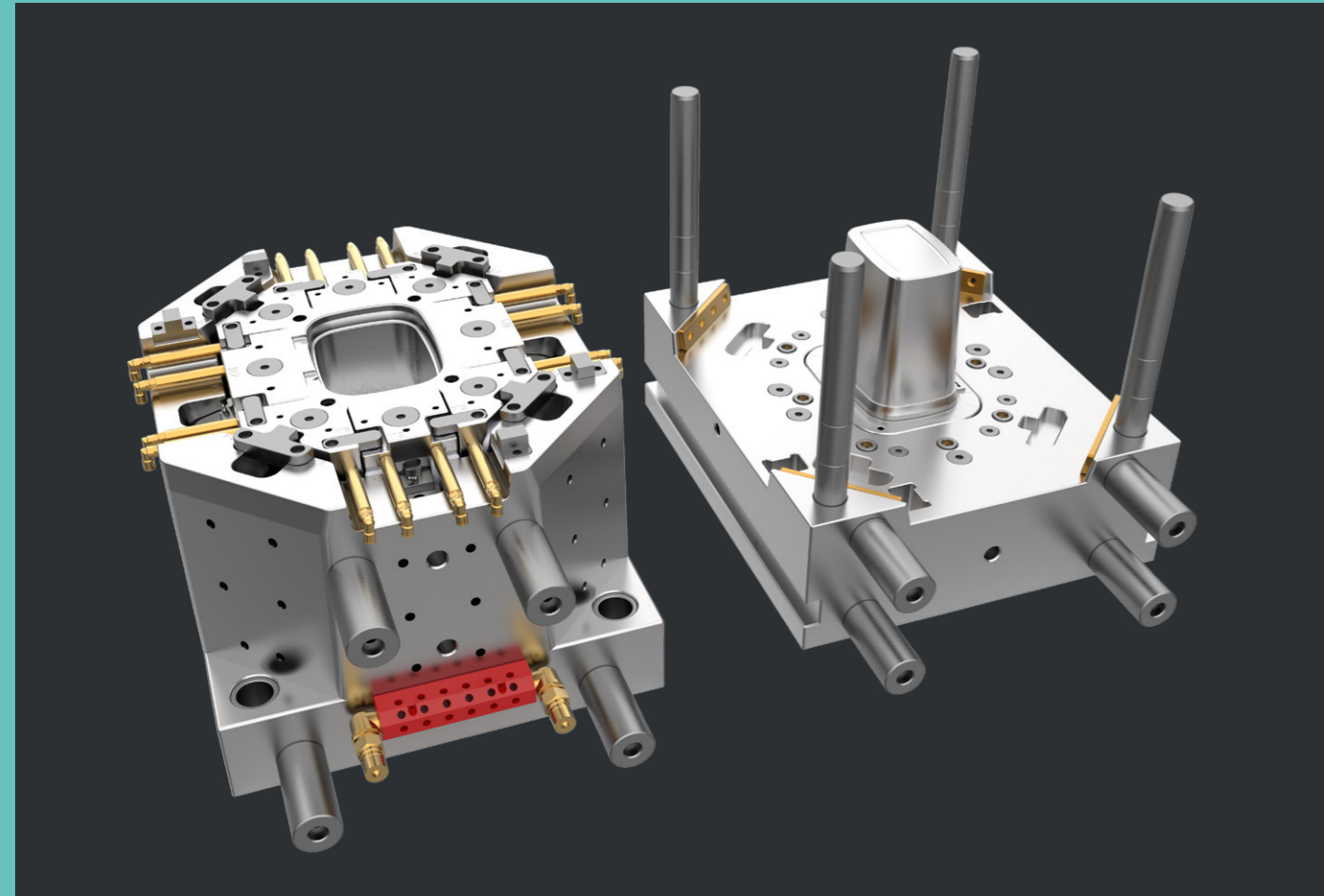

MILK COVER
MOLD

SÜT
KAPAĞI
KALIBI

Code: GK 0014

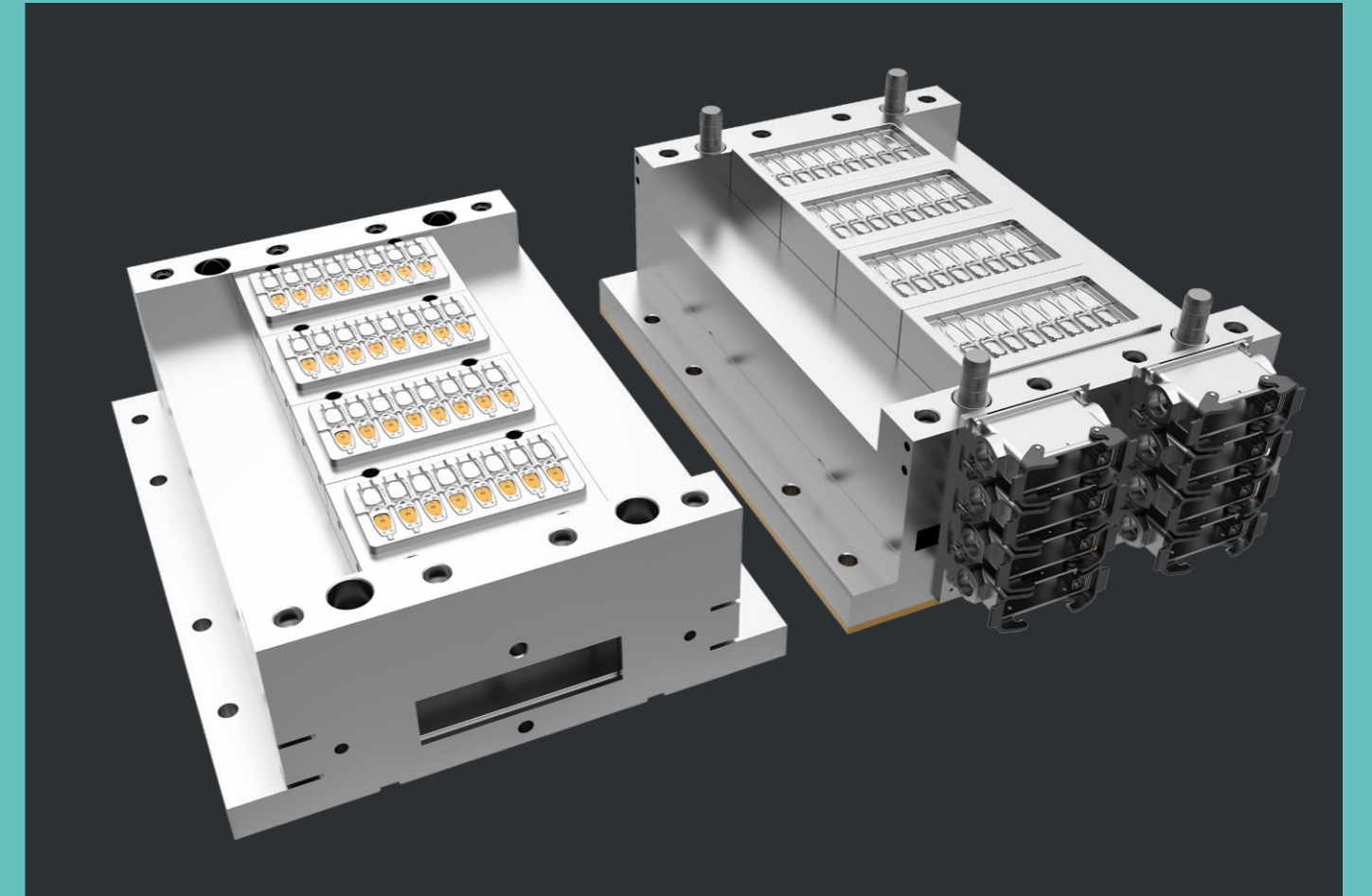

GLASS BOTTLE
DETERGENT
MOLD
CAM ŞİŞE
KAPAK
KALIBI



Code: GK 0015

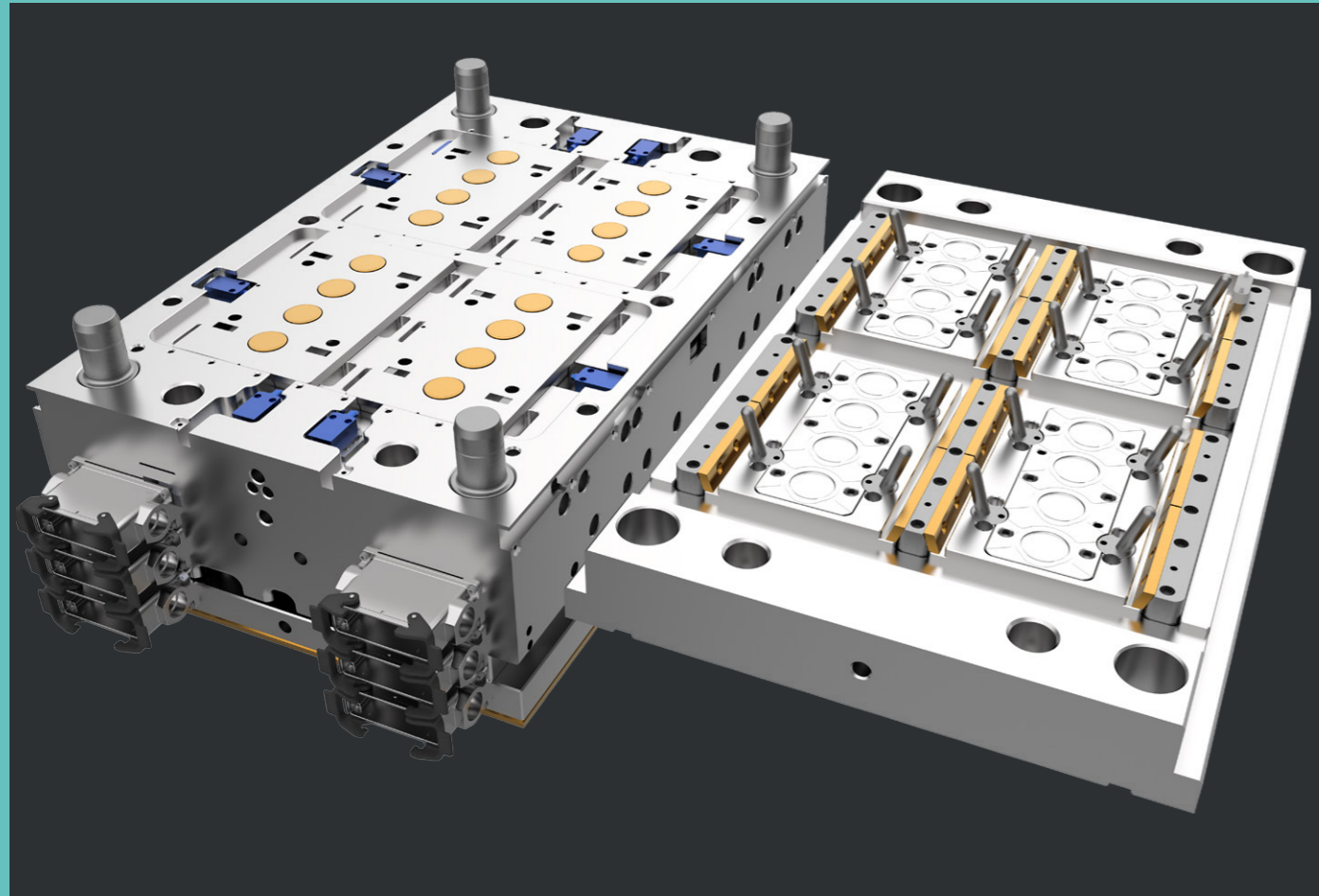

FOOD
CONTAINER
MOLD
ERZAK KABI
KALIBI



Code: GK 0016

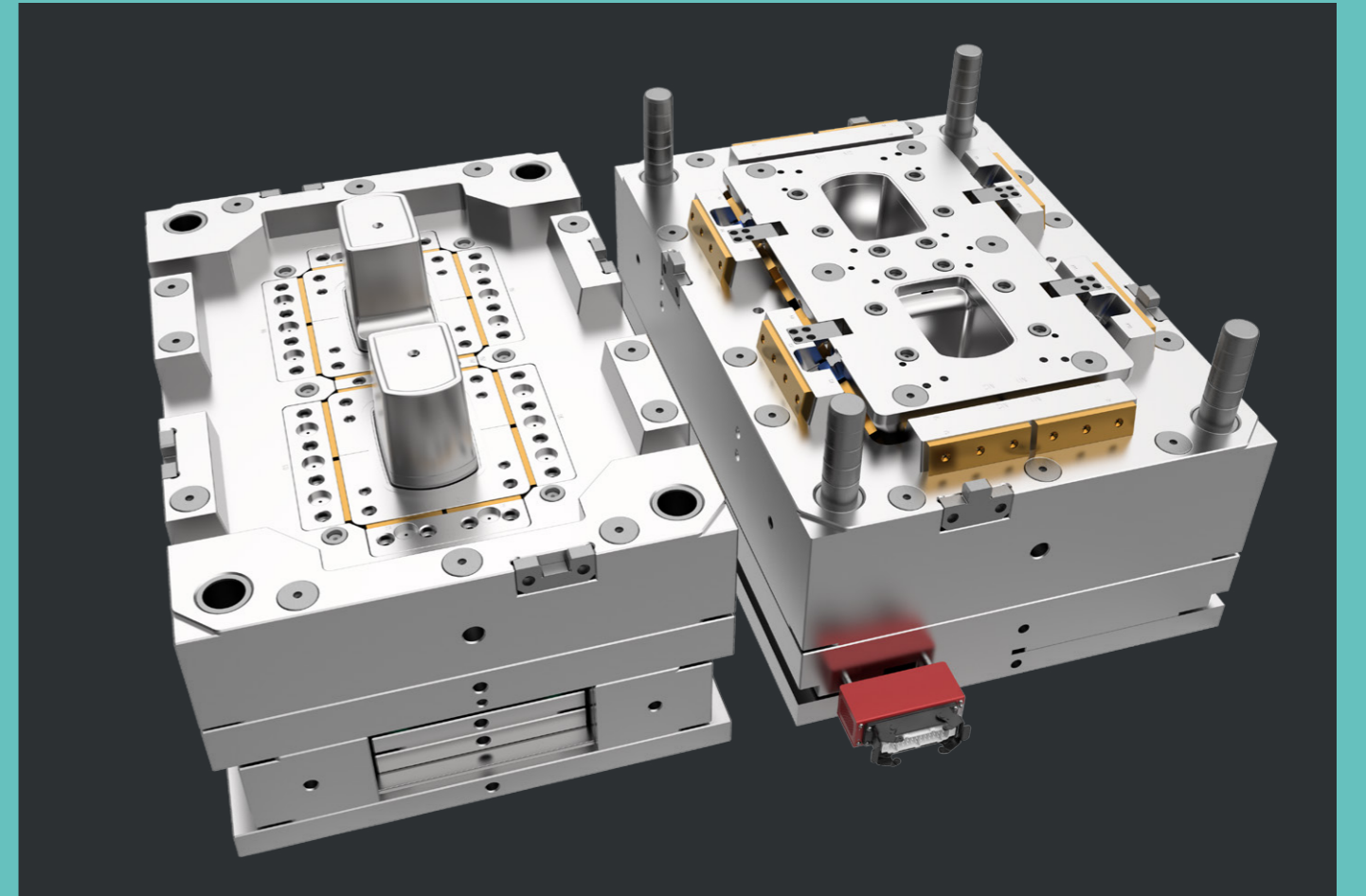

CNC Bölümü (4 Adet CNC Tezgâhi)

- DCV 2012 B = 900 x 1200 x 2000 = 4000
- NXV 1680 A = 700 x 762 x 1680 = 1500
- NMV 106 A = 600 x 600 x 1020 = 800
- MV 106 A = 600 x 600 x 1020 = 800

Mevcut CNC teknolojisinin son ürünü olan tezgâhlarımızda hata oranını en aza indiren CAD CAM programları ile termin sürelerine bağlı kalıp imalatı yapmaktayız.

Dalma Erezyon Bölümü Tezgâhları (3 Adet)

- 2 Adet ZET-NC Dalma Erezyon
- 1 Adet CNC Dalma Erezyon

Tüm erezyonlarımızda System 3R kullanılmaktadır.

Kalıphane Bölümü

- 1 Adet Taşlama Tezgâhi
- 3 Adet Kalıpcı Frezesi
- 1 Adet Ünersal Torna Tezgâhi
- 1 Adet Radyal Matkap
- 1 Adet Klavuz Çekme Makinesi

Kalıphanemizde kalıp üretimi için ihtiyaç duyulabilecek tüm makine teçhizat ve yazılımlar ile konusunda bilgi birikim ve tecrübeye sahip konusunda usta plastik kalıpcılar ile imalat yapılmaktadır.

CNC Machines Department

- DCV 2012 B = 900 x 1200 x 2000 = 4000
- NXV 1680 A = 700 x 762 x 1680 = 1500
- NMV 106 A = 600 x 600 x 1020 = 800
- MV 106 A = 600 x 600 x 1020 = 800

Now, there are 4 CNC machines with different sizes in our CNC Vertical Processing Center we increase the quality to the highest level and decrease the defect ratio to the minimum through CAD CAM programs that it can be reached by means of these machines, which are the latest products of cutting edge technology of today.

Sinking Erosion Department

Güvenç Mold EDM machines with high tonnage. Plastic Injection Mold is a solution partner for manufacturing customers.

Mold Manufacturing Department

All our molds for the production of machinery and software that may be needed by all our staff are professional and experienced team.

STARTS
WITH
PRODUCT
QUALITY
MOLD
ÜRÜNÜN
KALİTESİ
KALIP İLE
BAŞLAR



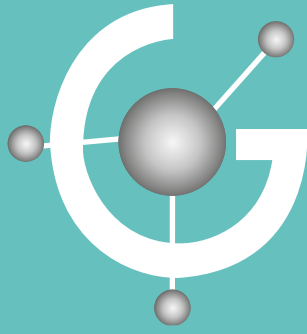

GÜVENÇ[®]
KALIP SANAYİ

Turkey

Discover
the potential



İkitelli O.S.B. İpkas Sanayi Sitesi 9-A Blok No: 27/29-
31/33 Başakşehir - İstanbul / TURKEY

Tel: +90 212 671 76 15 Fax: +90 212 671 76 05
samet@guvenckalip.com - sales@guvenckalip.com
info@guvenckalip.com - tasarim@guvenckalip.com

www.guvenckalip.com